

**YELLOW ZINC CUSHION CLAMPS**

PART #	MODEL #	DESCRIPTION (SIZE)	INNER CARTON QTY.	MASTER CARTON QTY.	MAKE SELECTION BELOW
<b>YELLOW ZINC CUSHION CLAMPS</b>					
H33699	HMCC14E	1/4" OD Yellow Zinc Cushion Clamp	50	200	<input type="checkbox"/>
H33674	HMCC38E	3/8" OD Yellow Zinc Cushion Clamp	50	200	<input type="checkbox"/>
H33675	HMCC12E	1/2" OD Yellow Zinc Cushion Clamp	50	200	<input type="checkbox"/>
H33676	HMCC58E	5/8" OD Yellow Zinc Cushion Clamp	50	200	<input type="checkbox"/>
H33677	HMCC34E	3/4" OD Yellow Zinc Cushion Clamp	50	200	<input type="checkbox"/>
H33678	HMCC78E	7/8" OD Yellow Zinc Cushion Clamp	50	200	<input type="checkbox"/>
H33679	HMCC118E	1-1/8" OD Yellow Zinc Cushion Clamp	50	200	<input type="checkbox"/>
H33680	HMCC138E	1-3/8" OD Yellow Zinc Cushion Clamp	50	100	<input type="checkbox"/>
H33681	HMCC158E	1-5/8" OD Yellow Zinc Cushion Clamp	50	100	<input type="checkbox"/>
H33682	HMCC218E	2-1/8" OD Yellow Zinc Cushion Clamp	50	100	<input type="checkbox"/>
H33683	HMCC258E	2-5/8" OD Yellow Zinc Cushion Clamp	25	100	<input type="checkbox"/>
H33684	HMCC318E	3-1/8" OD Yellow Zinc Cushion Clamp	25	100	<input type="checkbox"/>
H33685	HMCC418E	4-1/8" OD Yellow Zinc Cushion Clamp	25	100	<input type="checkbox"/>

**FINISH:** Yellow Zinc Carbon Steel

**FUNCTION:** Cushion Clamps are ideal for any application where shock, vibration and corrosion are a problem.

- FEATURES:**
- Maximum Temperature Rating: -50° F to +275°F
  - Assembled or disassembled with a single hand or power wrench for fast and simple installation
  - All metal components have a Tri-Valent (non-hex) plating
  - UL Classified 2043 (25/50) for use in plenums and air handling systems
  - Clamps are 1008 - 1010 Carbon Steel
  - Resists most fuels, oils, gases, greases, solvents, mineral acids and other harsh materials
  - Molded with High-Strength Thermoplastic Elastomer (TPE)

PAGE 1 of 2

JOB NAME:

---

JOB LOCATION:

---

CONTRACTOR:

---

DATE:

---

ITEM TAG:

---

ENGINEER APPROVAL:

---

DATE:

---

PART NUMBER:

---

YELLOW ZINC CUSHION CLAMPS

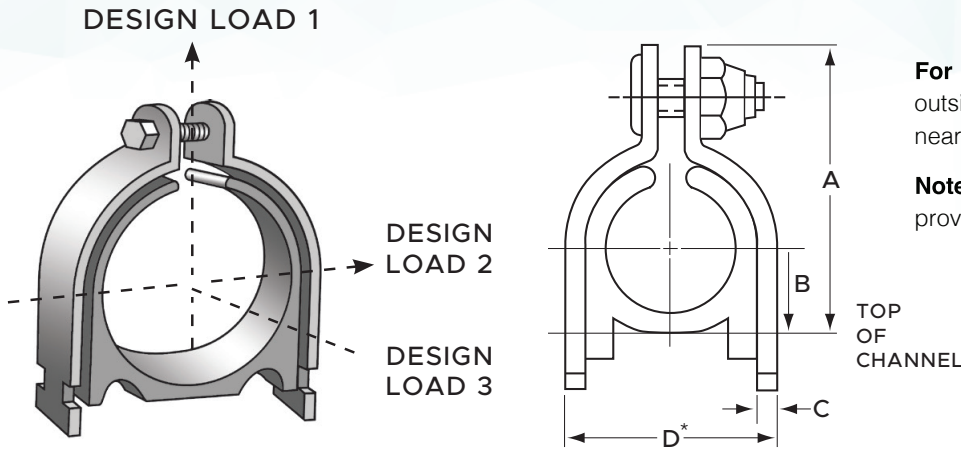

**For Hoses:** Measure hose outside diameter and select nearest OD size.

**Note:** Torque specification provided upon request.

PART #	MODEL #	OD	LOAD 1	LOAD 2	LOAD 3	A	B	C	D
H33699	HMCC14E	1/4"	400	50	50	1.11	.22	.075	.62
H33674	HMCC38E	3/8"	400	50	50	1.24	.28	.075	.75
H33675	HMCC12E	1/2"	400	50	50	1.36	.34	.075	.87
H33676	HMCC58E	5/8"	400	50	50	1.50	.41	.075	1.00
H33677	HMCC34E	3/4"	600	75	75	1.78	.53	.075	1.33
H33678	HMCC78E	7/8"	600	75	75	1.91	.58	.075	1.45
H33679	HMCC118E	1-1/8"	600	75	75	2.16	.72	.075	1.79
H33680	HMCC138E	1-3/8"	600	75	75	2.75	.91	.119	2.22
H33681	HMCC158E	1-5/8"	600	75	75	3.03	1.03	.119	2.47
H33682	HMCC218E	2-1/8"	800	125	125	3.53	1.28	.119	2.97
H33683	HMCC258E	2-5/8"	800	125	125	4.03	1.53	.119	3.47
H33684	HMCC318E	3-1/8"	800	125	125	4.52	1.78	.119	3.97
H33685	HMCC418E	4-1/8"	1000	200	150	5.66	2.34	.119	5.09

JOB NAME: \_\_\_\_\_

JOB LOCATION: \_\_\_\_\_

CONTRACTOR: \_\_\_\_\_ DATE: \_\_\_\_\_

ITEM TAG: \_\_\_\_\_

ENGINEER APPROVAL: \_\_\_\_\_ DATE: \_\_\_\_\_

PART NUMBER: \_\_\_\_\_