

# STUD SHOE BRACKETS (18 GAUGE)

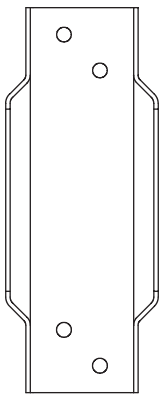

Part #	Model #	Description (Size)	Inner Carton Qty	Master Carton Qty	Select Model Below
<b>STUD SHOE BRACKETS (18 GAUGE)</b>					
H19735	<b>HMSS18</b>	SINGLE STUD SHOE BRACKET - 18 GAUGE	-	25	<input type="checkbox"/>
H19736	<b>HMSSD18</b>	DOUBLE STUD SHOE BRACKET - 18 GAUGE	-	25	<input type="checkbox"/>
H19737	<b>HMSST18</b>	TRIPLE STUD SHOE BRACKET - 18 GAUGE	-	25	<input type="checkbox"/>



PART #	WIDTH	MAX LOAD	AVG. ULT.	NAILS
H19735	1.50	552 LBS.	3255 LBS.	12-10d x 1.5
H19736	3.00	810 LBS.	6568 LBS.	12-10d
H19737	4.50	945 LBS.	7489 LBS.	14-10d

**MADE IN THE USA**

## MATERIALS

- STEEL - 18 GAUGE

**ADDITIONAL SIZES  
NOT PICTURED ABOVE**

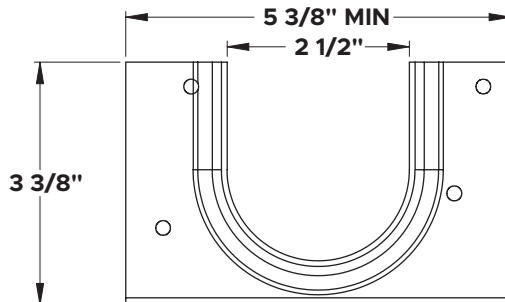
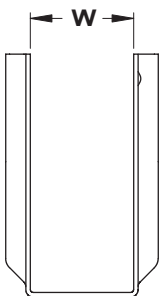

**NOT A TOTAL  
REPLACEMENT FOR  
MATERIAL REMOVED**

**INSTALL PER  
DIRECTIONS**

**INSTALL PER  
LOCAL BUILDING  
CODES**

**HMSSD18**



**HMSST18**



**JOB NAME:** \_\_\_\_\_

**JOB LOCATION:** \_\_\_\_\_

**CONTRACTOR:** \_\_\_\_\_

**DATE:** \_\_\_\_\_

**ITEM TAG:** \_\_\_\_\_

**ENGINEER APPROVAL:** \_\_\_\_\_

**DATE:** \_\_\_\_\_

**PART NUMBER:** \_\_\_\_\_