

62 GAL. WELL TANK



NEW!		PART #	MODEL #	DESCRIPTION	INNER CARTON QTY	PALLET QTY.	SELECT MODEL BELOW
62 GALLON WELL TANK							
H10015	HPWT62	62 GALLON WELL TANK (1-1/4" Connection Size)		1	-	<input type="checkbox"/>	

SYSTEM CONFIGURATION

SPECIFICATION INFORMATION

Shell: **Cold Rolled Carbon Steel**
 Finish: **Triple Layer Electrostatic Paint**
 Diaphragm: **Butyl Rubber**
 Liner: **Antimicrobial Polypropylene**
 Connection: **304 Stainless Steel**
 Base: **Steel**
 Pre-Charge: **45 PSI**
 Max Pressure: **150 PSI**
 Max Temp: **200° F**

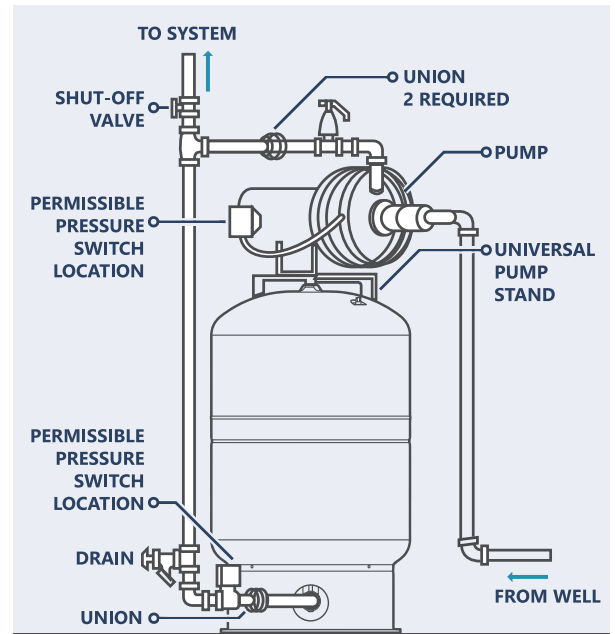
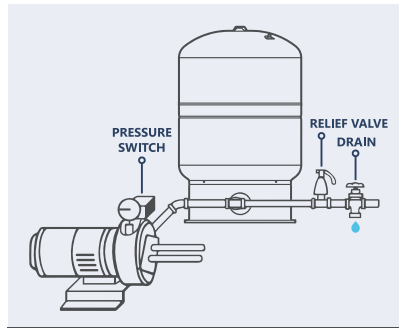

PAGE 1 of 2

DIAMETER (INCH)	HEIGHT (INCH)	DRAWDOWN IN GALS 30/50 PSIG	DRAWDOWN IN GALS 40/60 PSIG	DRAWDOWN IN GALS 50/70 PSIG	BOX LENGTH (INCH)	BOX WIDTH (INCH)	BOX HEIGHT (INCH)	BOX WEIGHT (LBS)	FACTORY PRE-CHARGE	CONNECTION
21.7	47.1	20.1	17	15.3	22.1	22.1	47.9	83.2	45 PSI	1-1/4"

JOB NAME: _____

JOB LOCATION: _____

CONTRACTOR: _____ DATE: _____

ITEM TAG: _____

ENGINEER APPROVAL: _____ DATE: _____

PART NUMBER: _____

62 GAL. WELL TANK



NEW!		PART #	MODEL #	DESCRIPTION	INNER CARTON QTY	PALLET QTY.	SELECT MODEL BELOW
62 GALLON WELL TANK							
H10015	HPWT62	62 GALLON WELL TANK (1-1/4" Connection Size)		1	-	<input type="checkbox"/>	

DIMENSIONS & SYSTEM COMPONENTS

A	1-1/4" STAINLESS STEEL CONNECTION 304
B	BUTYL RUBBER DIAPHRAGM
C	AIR VALVE
D	WELD AREA

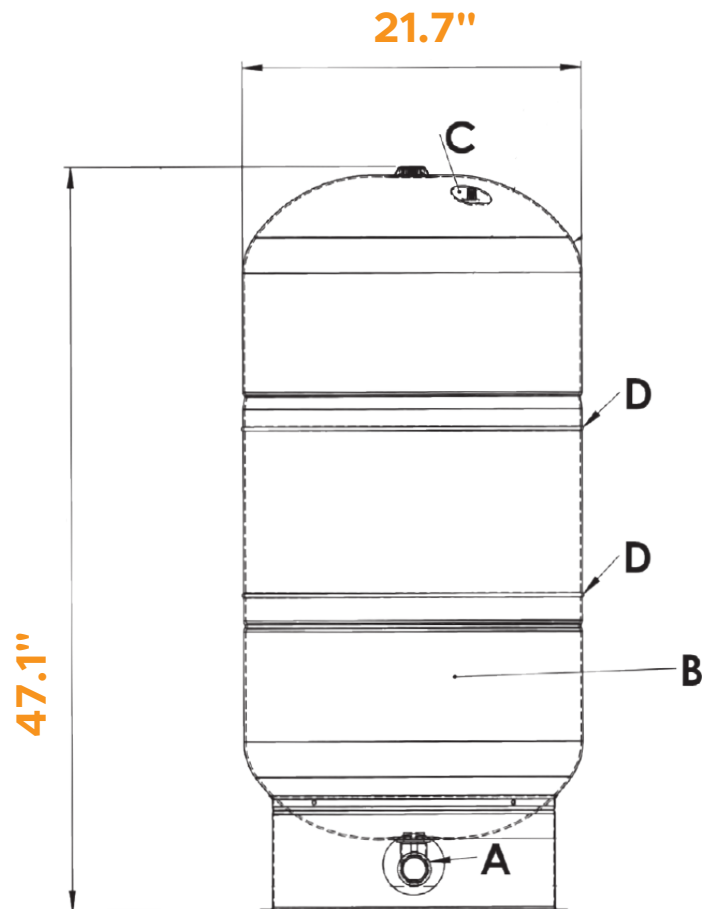

PAGE 2 of 2

JOB NAME:

JOB LOCATION:

CONTRACTOR:

ENGINEER APPROVAL:

DATE:

DATE:

ITEM TAG:

PART NUMBER: