

STUD SHOE BRACKETS (16 GAUGE)



Part #	Model #	Description (Size)	Inner Carton Qty	Master Carton Qty	Select Model Below
STUD SHOE BRACKETS (16 GAUGE)					
H19732	HMSS16	SINGLE STUD SHOE BRACKET - 16 GAUGE	-	25	<input type="checkbox"/>
H19733	HMSSD16	DOUBLE STUD SHOE BRACKET - 16 GAUGE	-	25	<input type="checkbox"/>
H19734	HMSST16	TRIPLE STUD SHOE BRACKET - 16 GAUGE	-	25	<input type="checkbox"/>

PART #	WIDTH	MAX LOAD	AVG. ULT.	NAILS
H19735	1.50	552 LBS.	3255 LBS.	12-10d x 1.5
H19736	3.00	810 LBS.	6568 LBS.	12-10d
H19737	4.50	945 LBS.	7489 LBS.	14-10d

MADE IN THE USA

MATERIALS

• STEEL - 16 GAUGE

**ADDITIONAL SIZES
NOT PICTURED ABOVE**

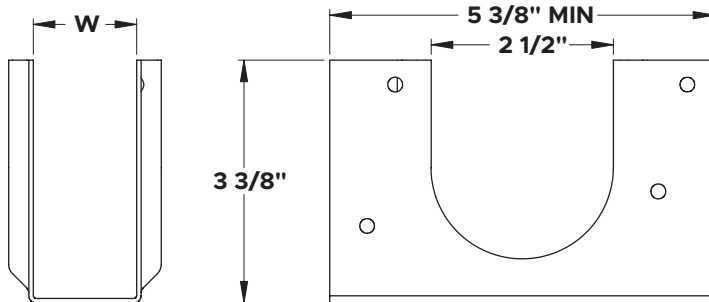

**NOT A TOTAL
REPLACEMENT FOR
MATERIAL REMOVED**

**INSTALL PER
DIRECTIONS**

**INSTALL PER
LOCAL BUILDING
CODES**

HMSSD16



HMSST16



JOB NAME: _____

JOB LOCATION: _____

CONTRACTOR: _____ **DATE:** _____ **ITEM TAG:** _____

ENGINEER APPROVAL: _____ **DATE:** _____ **PART NUMBER:** _____