

BEVELED STUD SHOE BRACKETS (16 GAUGE)

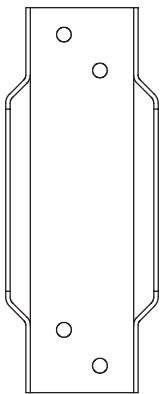

Part #	Model #	Description (Size)	Inner Carton Qty	Master Carton Qty	Select Model Below
BEVELED STUD SHOE BRACKETS (16 GAUGE)					
H19747	HMSSS16B	BEVELED SINGLE STUD SHOE BRACKET - 16 GAUGE	-	25	<input type="checkbox"/>
H19748	HMSSD16B	BEVELED DOUBLE STUD SHOE BRACKET - 16 GAUGE	-	25	<input type="checkbox"/>
H19749	HMSST16B	BEVELED TRIPLE STUD SHOE BRACKET - 16 GAUGE	-	10	<input type="checkbox"/>



PART #	WIDTH	MAX LOAD	AVG. ULT.	NAILS
H19747	1.50	552 LBS.	3255 LBS.	12-10d x 1.5
H19748	3.00	810 LBS.	6568 LBS.	12-10d
H19749	4.50	945 LBS.	7489 LBS.	14-10d

MADE IN THE USA

MATERIALS

• STEEL - 16 GAUGE

**ADDITIONAL SIZES
NOT PICTURED ABOVE**

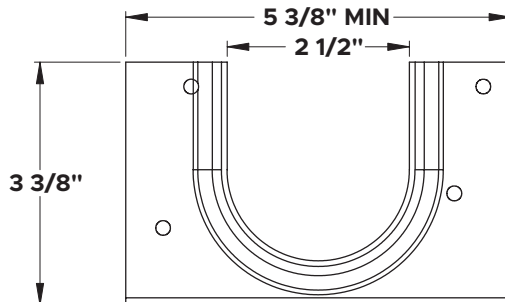
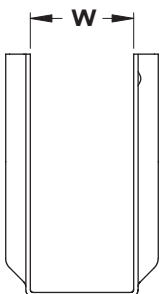

**NOT A TOTAL
REPLACEMENT FOR
MATERIAL REMOVED**

**INSTALL PER
DIRECTIONS**

**INSTALL PER
LOCAL BUILDING
CODES**

HMSSD16B



HMSST16B



JOB NAME: _____

JOB LOCATION: _____

CONTRACTOR: _____ **DATE:** _____ **ITEM TAG:** _____

ENGINEER APPROVAL: _____ **DATE:** _____ **PART NUMBER:** _____