

SERVICE WEIGHT MULTI-TITE GASKETS

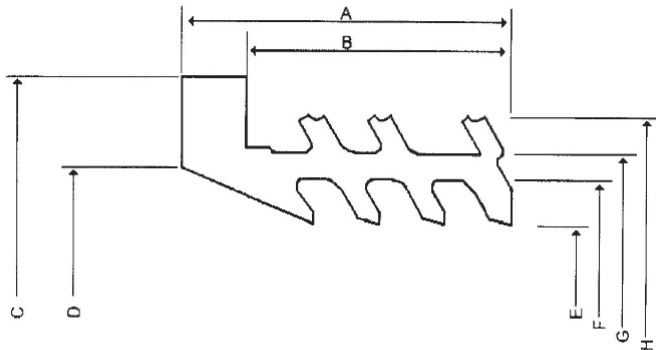

PART #	MODEL #	DESCRIPTION	INNER CARTON QTY.	MASTER CARTON QTY.	SELECT MODEL BELOW
SERVICE WEIGHT MULTI-TITE GASKETS					
H99950	HPSWG2	2" SERVICE WEIGHT MULTI-TITE GASKET	1	150	<input type="checkbox"/>
H99951	HPSWG3	3" SERVICE WEIGHT MULTI-TITE GASKET	1	100	<input type="checkbox"/>
H99952	HPSWG4	4" SERVICE WEIGHT MULTI-TITE GASKET	1	60	<input type="checkbox"/>
H99953	HPSWG5	5" SERVICE WEIGHT MULTI-TITE GASKET	1	40	<input type="checkbox"/>
H99954	HPSWG6	6" SERVICE WEIGHT MULTI-TITE GASKET	1	30	<input type="checkbox"/>
H99955	HPSWG8	8" SERVICE WEIGHT MULTI-TITE GASKET	1	20	<input type="checkbox"/>
H99956	HPSWG10	10" SERVICE WEIGHT MULTI-TITE GASKET	1	10	<input type="checkbox"/>
H99957	HPSWG12	12" SERVICE WEIGHT MULTI-TITE GASKET	1	10	<input type="checkbox"/>

- Compression Gasket Used to Join Hub and Spigot Cast Iron Pipe and Fittings in a DWV System
- Meets ASTM C564
- One-Piece Molded Elastomeric Sealing Gasket
- Lubricant Required with Gaskets (not provided)
- Gaskets are Made In The USA



Size	A	B	C	D	E	F	G	H
2"	1.800	1.450	3.600	2.600	1.950	2.330	2.690	3.070
3"	1.800	1.450	4.650	3.710	3.040	3.420	3.780	4.160
4"	1.800	1.430	5.700	4.710	4.080	4.500	4.880	5.220
5"	2.180	2.540	6.750	5.640	4.980	5.440	5.820	6.160
6"	2.160	1.600	7.750	6.610	6.020	6.500	6.820	7.200
8"	2.500	2.090	9.880	8.720	7.920	8.460	8.960	9.420
10"	2.540	2.050	12.370	10.880	10.180	10.700	11.220	11.680
12"	2.940	2.460	14.250	13.000	12.210	12.770	13.330	13.800

JOB NAME:

JOB LOCATION:

CONTRACTOR:

DATE:

ITEM TAG:

ENGINEER APPROVAL:

DATE:

PART NUMBER: