

THREADED x F1960 PEX BRASS BALL VALVES



PART #	MODEL #	DESCRIPTION (SIZE)	INNER CARTON QTY.	MASTER CARTON QTY.	SELECT MODEL BELOW
BRASS BALL VALVES (MIP x F1960 PEX)					
H50076	IBVMWP600LF34	3/4" x 3/4" BRASS F1960 PEX BALL VALVE	10	60	<input type="checkbox"/>

FEATURES & BENEFITS

- PEX Ball Valve
- Brass Body
- MIP X ASTM F1960 PEX
- 400 WOG
- Chrome Plated Brass Ball
- cUPC Certified and Lead-Free



DN	W	H	L
0.611	2.89	1.81	3.46

NO.	PART	MATERIAL
1	Body	Lead-Free Brass
2	Seat	PTFE
3	Ball	Stainless Steel
4	O-Ring	NBR
5	Packing	PTFE
6	Stem	Brass
7	Handle Nut	Plated Steel
8	Handle	Plated Steel
9	Packing Nut	Brass
10	Cap	Lead-Free Brass

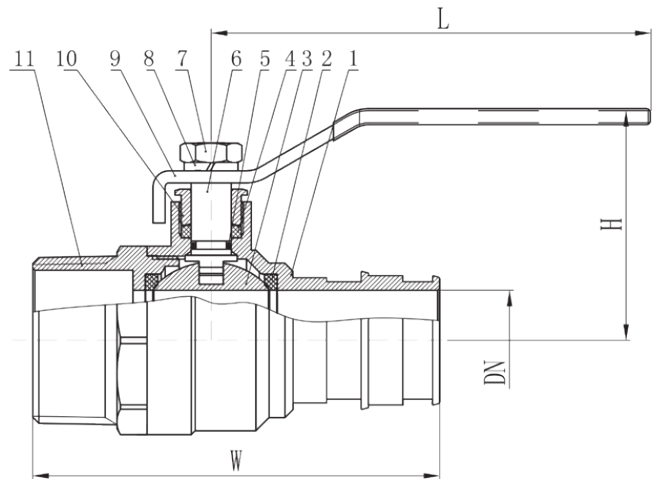

JOB NAME:

JOB LOCATION:

CONTRACTOR:

ENGINEER APPROVAL:

DATE:

DATE:

ITEM TAG:

PART NUMBER: