

20 GAL. HORIZONTAL WELL TANK



PART #	MODEL #	DESCRIPTION	INNER CARTON QTY	PALLET QTY.	SELECT MODEL BELOW
20 GALLON WELL TANK					
H10025	HPWT20H	20 GALLON WELL TANK HORIZONTAL	1	-	<input type="checkbox"/>



SYSTEM CONFIGURATION

SPECIFICATION INFORMATION

Shell: Cold Rolled Carbon Steel
 Finish: Triple Layer Electrostatic Paint
 Diaphragm: Butyl Rubber
 Liner: Antimicrobial Polypropylene
 Connection: 304 Stainless Steel
 Base: Plastic
 Pre-Charge: 40 PSI
 Max Pressure: 150 PSI
 Max Temp: 200° F

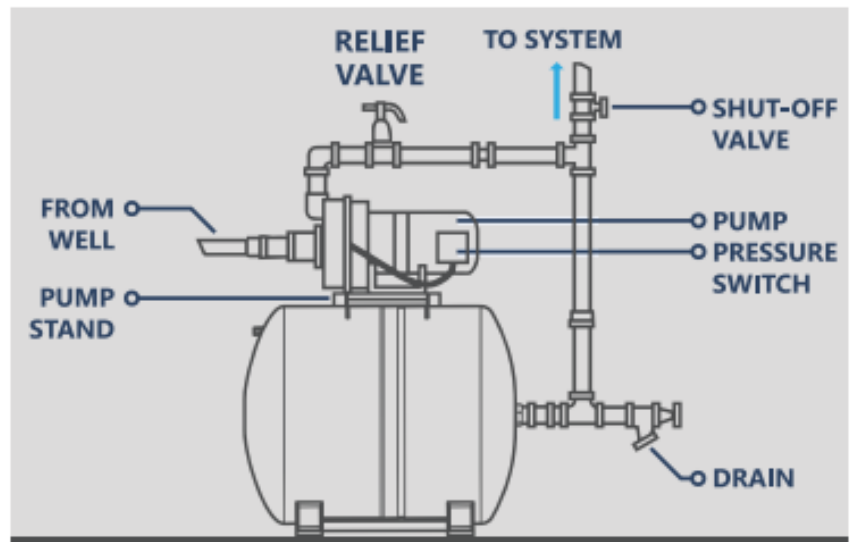

TANK INCLUDES PLASTIC PUMP STAND

DIAMETER (INCH)	HEIGHT (INCH)	LENGTH (INCH)	DRAWDOWN IN GALS 30/50 PSIG	DRAWDOWN IN GALS 40/60 PSIG	DRAWDOWN IN GALS 50/70 PSIG	BOX LENGTH (INCH)	BOX WIDTH (INCH)	BOX HEIGHT (INCH)	BOX WEIGHT (LBS)	CONNECTION
15	17	30	6.8	6	5.5	29.2	15.7	17.3	32.5	1"

JOB NAME: _____

JOB LOCATION: _____

CONTRACTOR: _____ DATE: _____

ENGINEER APPROVAL: _____ DATE: _____

ITEM TAG: _____

PART NUMBER: _____

20 GAL. HORIZONTAL WELL TANK



PART #	MODEL #	DESCRIPTION	INNER CARTON QTY	PALLET QTY.	SELECT MODEL BELOW
20 GALLON WELL TANK					
H10025	HPWT20H	20 GALLON WELL TANK HORIZONTAL	1	-	<input type="checkbox"/>



DIMENSIONS & SYSTEM COMPONENTS

A	1" STAINLESS STEEL CONNECTION 304
B	BUTYL RUBBER DIAPHRAGM
C	AIR VALVE
D	WELD AREA

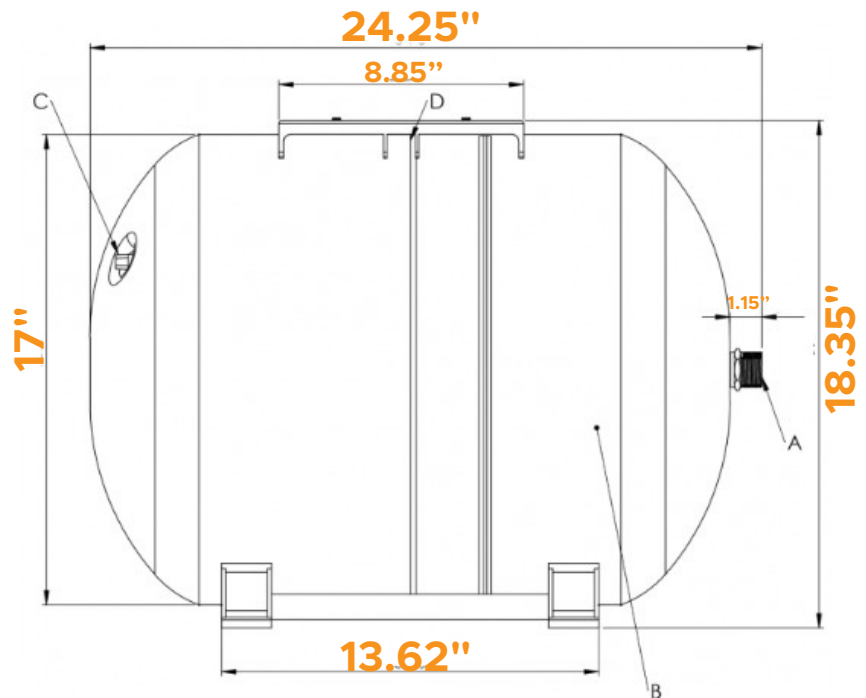

PAGE 2 of 2

JOB NAME: _____

JOB LOCATION: _____

CONTRACTOR: _____ DATE: _____

ENGINEER APPROVAL: _____ DATE: _____

ITEM TAG: _____

PART NUMBER: _____